

# TURMOIL

WEST SWANZEY, NH 03469  
603-352-0053

## INSTALLATION, MAINTENANCE and OPERATION MANUAL

MODEL OC-200 R

### TABLE OF CONTENTS

<u>Description</u>	<u>Page</u>
Unpacking & Inspection	2
Cooler Placement	2
Description	2
Plumbing Hook-up	2
System Filling	3
Electrical Hook-up	3
Temperature Controller	3
Start-up	3
Operation	4
Pump Pressure Adjustment	4
Safety Interlocks	4, 5
Refrigerant Pressures	5
Maintenance	5
Parts List	6
Troubleshooting	7
Electrical Diagram	8

10/30/06

Model OC-200 R continued

---

## **WARNING**

---

**DO NOT ATTEMPT TO START UP THIS COOLER UNTIL YOU HAVE READ THROUGH THE INSTRUCTIONS COMPLETELY. IMPROPER START-UP WILL VOID THE COOLER WARRANTY AND DAMAGE THE MACHINE.**

---

### **UNCRATING & INSPECTION**

Rough handling during shipment may cause obvious and/or concealed damage. Upon arrival, the cooler should be inspected carefully and claims for damage must be filed immediately with the trucker.

When uncrating the cooler, inspect it thoroughly for signs of concealed damage. Coolers that have been dropped or shipped on their side may not show external damage. If damages are found, a claim must be filed with the carrier within 30 days of delivery.

The cooler is shipped fully charged with refrigerant and ready for operation. The cooler has been run for at least 4 hours under full load conditions before shipment.

### **COOLER PLACEMENT**

Place the cooler in a level location where it is accessible from the right side and front and with enough room to make electrical and hose connections.

The cooler will draw air in through the air filter on the rear panel and exhale air through the top. The cooler must be placed in an area where air intake and discharge are not impeded. Lack of adequate air flow will cause a reduction in cooling capacity and/or completely shutdown the refrigeration system. A minimum of two feet of open space on air intake and discharge sides is recommended. The cooler is provided with an air intake filter. This filter must be kept clean.

### **DESCRIPTION**

The OC-200 R is a completely self-contained recirculating coolant cooler consisting of a reservoir, digital temperature controller, circulating pump and air cooled refrigeration system. After the unit is filled with coolant and the proper electrical and plumbing connections are made, the OC-200 R will operate virtually maintenance free, supplying coolant at constant temperature and pressure.

This cooler is designed for use indoors in a clean industrial environment. Ambient temperature should not fall below 55° F (13° C) or rise above 100° F (38° C). The OC-200 R is capable of removing heat at the rate of 24,000 Btu/Hr, while cooling a water based coolant to 60° F in a 90° F ambient.

### **PLUMBING HOOK-UP**

Make hose connections to the 3/4" FPT fittings on the lower front panel tagged DISCHARGE and RETURN. Coolant flow will be out the DISCHARGE connection.

### **SYSTEM FILLING**

To fill the 12 gallon coolant tank, untwist and remove the fill port cap located on the lower front panel and fill the reservoir to the top of the level gauge. Do not overfill. After the cooler has operated for a few minutes, add more coolant as necessary to fill the tank.

*Model OC-200 R continued***ELECTRICAL HOOK-UP**

See the electrical diagram attached. This cooler is wired for 230 volt, 60 hertz, 3 phase power supply. Check the nameplate tag on the door of the electrical enclosure to verify proper voltage. The supply voltage must be within 10% of the rated voltage on the tag. Make power connections to the terminals provided on the disconnect switch in the NEMA-12 electrical enclosure. Connect ground to the grounding terminals provided.

Terminals #20 and #21 are wired to a HIGH TEMP interlock switch. This switch opens when the coolant temperature exceeds a high temperature setting (See the attached temperature controller instructions on adjusting this setting). Terminals #22 and #23 are wired to a LOW FLOW interlock switch. This switch opens if the flow of coolant returning to the cooler drops below 5 GPM.

**TEMPERATURE CONTROLLER**

This cooler is supplied with a digital temperature controller (CTC-106) mounted on the door of the electrical enclosure. See the attached instruction sheet for operating this controller. The controller maintains the oil temperature within  $\pm 0.5^{\circ}$  F of the adjustable set-point. The temperature sensor is installed in the DISCHARGE line. The controller will alternate flashing the set point temperature (S) and the actual temperature (F).

**START-UP**

When power is supplied to the cooler and the rotary disconnect switch is turned to the ON position, the white POWER ON light will come on as will the display on the controller. Set the controller to the desired coolant temperature.

The cooler is started by turning the PUMP ON/OFF switch to the ON position. A green PUMP ON light on the front panel will come on and the pump, compressor and fan will start and run continuously. **Immediately upon start-up, check the circulating pump for prime and proper motor rotation** by viewing the red LOW FLOW light and the DISCHARGE pressure gauge. If the pump is primed and rotating in the proper direction, the red LOW FLOW light will go out as the circulating pump starts circulating coolant. The DISCHARGE pressure gauge should also show pressure. If the red LOW FLOW light does not go out or the pressure gauge shows little or no pressure, turn off the pump and check the prime by loosening the priming plug on the top of the pump. Let entrapped air escape through the plug hole until coolant starts dripping out then retighten the plug. The circulating pump may be accessed by removing the lower right side panel. Turn the pump back on. If the pressure gauge still does not show significant pressure, turn off the pump and then turn off the power supply to the cooler and exchange any two of the power leads to the disconnect switch. Turn the power supply back on and start up the pump again. The circulating pump rotation can also be checked by viewing the pump motor shaft. Remove the lower right side panel to view the pump. Rotation should be counter-clockwise as viewed from the motor end of the pump. **Do not run the pumps for more than 15 seconds without flow.** The compressor and fan will not run if the red LOW FLOW light is on.

Check for plumbing leaks and make any necessary repairs. Check the coolant level after the few minutes it takes for the pump to circulate coolant through the external loop. Add more coolant as necessary to fill the tank.

**OPERATION**

When power is supplied to the cooler and the PUMP OFF/ON switch is turned to the ON position, the green PUMP ON light comes on and the pump starts and runs continuously. Once coolant has

*Model OC-200 R continued*

circulated through the coolant loop the red LOW FLOW light goes out and the compressor and fan start up and run continuously. Set the temperature controller to the desired temperature.

When the controller calls for cooling, the solenoid valve on the liquid line is open and refrigerant flows through the expansion valve to absorb heat and evaporate in the evaporator/heat exchanger located outside the sump. When the controller calls for heating, the solenoid valve on the liquid line closes, stopping the flow of refrigerant to the expansion valve. The compressor keeps running, pumping refrigerant out of the evaporator causing the suction pressure to drop. When the suction pressure drops to about 25 psi, the hot gas bypass valve opens, allowing hot refrigerant gas to bypass the condenser and enter directly into the evaporator where it is cooled by the circulating coolant. The cooler should now be ready for continuous operation.

**PUMP PRESSURE ADJUSTMENT**

An adjustable pressure relief bypass valve has been installed in the discharge line to limit the maximum pump pressure that can be developed. The pressure relief bypass valve has been factory set to open at 50 psi. The pressure can be adjusted from 25 to 100 psi by adjusting the pressure relief bypass valve. To adjust the pressure at which the valve opens, turn the adjusting bolt on the relief valve clockwise to increase pressure and counterclockwise to decrease pressure. When increasing pressure, be sure to check the pump motor amperage to make sure it does not exceed the rating of the motor.

**SAFETY INTERLOCKS****HIGH/LOW PRESSURE SWITCH**

The compressor is protected from excessively high discharge pressure or low suction pressure by HIGH/LOW pressure switch mounted inside the cabinet. High head pressure can be caused by a dirty air filter or condenser or by blocking off air flow through the condenser. High head pressure can also be caused by a faulty solenoid valve. Low suction pressure can be caused by loss of refrigerant charge, operating at too low a coolant temperature (below 50° F), a faulty solenoid valve or too little flow of coolant through the evaporator.

The High/Low pressure switch is factory set as follows:

High Pressure Cut Out:	250 #
Suction Pressure Cut In:	35 #
Differential:	25 #

If the cooler shuts down on the Low Pressure switch, it will come back on after the pressure has built back-up. If the cooler continuously cycles on the Low Pressure switch, it most likely is operating at too low a coolant temperature or has a low refrigerant charge.

If the cooler shuts down on the High Pressure switch, it will stay off until the Blue reset button on the High/Low pressure switch is pushed in. If the cooler goes cut on High Pressure, most likely the condenser or the condenser filter is clogged or blocked.

**LOW FLOW INTERLOCK**

The cooler is supplied with a flow switch to prevent damage to the process due to loss of coolant flow. When coolant flow returning to the cooler drops below 5 GPM, the switch contacts wired to terminals #22 and #23 will open, the red LOW FLOW light will come on and the compressor and fan will shut down.

*Model OC-200 R continued***HIGH TEMPERATURE INTERLOCK**

The cooler is also supplied with HIGH TEMP interlock. This interlock is activated by an auxiliary relay (K2) on the temperature controller (CTC). The HIGH TEMP warning indicates that the coolant discharge temperature has exceeded a preset limit. On HIGH TEMP fault, the cooler will continue to operate but the contacts across terminals #20 and #21 will open. See the attached temperature controller instructions for setting this limit.

**MAINTENANCE**

Every Turmoil cooler is carefully assembled from the finest components by skilled craftsmen. Each cooler is thoroughly tested and inspected before it leaves the factory. However, in order to obtain efficient service and long life from this cooler, it must be given proper care as with any other piece of mechanical equipment.

Once each week check the coolant level in the system reservoir. Replenish as required any loss to evaporation. The coolant must be kept clean, and should be changed every 2000 hours of operation or at least once a year.

**AIR FILTER:** Keep Clean

**CONDENSER:** Condenser fins should be cleaned of dust and dirt regularly.

**PUMPS:** See Pump instructions attached

## Model CC-200 IL-CTC continued

## PART LIST

SYMBOL	DESCRIPTION	MFG / MODEL	PART NO
FLTR	AIR FILTER	SMITH /	550001
TEV	THERMO EXPANSION VALVE	DANFOS / TU8	140301
3MTR	COMPRESSOR	MANEUROP / MTZ-36 JG4	110201
COND	CONDENSER	HEATCRAFT / 22 X 22	130201
HGBV	HOT GAS BYPASS VALVE	DANFOSS / CPCE-12	180601
DRY	DRIER	ALCO / EK083S	172381
EVAP	EVAPORATOR	WTT / WP4-20	120751
FB	FAN BLADE	TECUMSEH / 2HP	130202
4MTR	FAN MOTOR -1/4HP	A O SMITH / F48B09A12	135251
3FU	FUSE - 1.25A	BUSSMAN / FNM-1.25	211011
1FU	FUSE - 25A	BUSSMAN / LPCC-25	211151
2FU	FUSE - 1A	BUSSMAN / LPCC-1	211011
H/L PS	HIGH/LOW PRESSURE SWITCH	ALCO / 215-S7	152001
G	LIGHT - GREEN, PILOT	S&S / D5P-PM3D5	247001
W	LIGHT - WHITE, PILOT	S&S / D5P-PM2D5	247002
PUMF	PUMP	GRUNDFOS / CHI-2-40	410501
LG	LEVEL GAUGE	THOMAS/4400	62011
1MTR	PUMP MOTOR	GRUNDFOS /	460501
FS	FLOW SWITCH	THOMAS / 12669	620201
REC	RECEIVER	TECUMSEH / 51081-2	170801
EYE	REFRIGERANT SIGHT GLASS	DANFOSS / SGN10S	171381
SOL	SOLENOID (COIL)	DANFOSS / 018Z7612	161201
VAL	SOLENOID VALVE	DANFOSS / EVR6	160101
SW	SWITCH - ON/OFF	S&S / D5P	248001
CTC	TEMPERATURE CONTROLLER	THERMOLOGIC / CTC-106	610641
TS	TEMPERATURE SENSOR	THERMOLOGIC / 1122-136	610001
TX	TRANSFORMER	ACME / TA-2-81211	230101
FP	FILL PORT CAP	FLOW EZY / AM-1100-3	630121
SG	SIGHT GLASS (ALUMINUM)	LUBE DEVICES / G605-05-A-1	640051
3M	CONTACTOR, COMPRESSOR	S&S / CA 4-9-10	201091
1M	CONTACTOR, PUMP	S&S / CA 4-9-10	201091
1OL	OVERLOAD, PUMP	S&S / CT4-9 (1.2)	200001
PRBV	PRESSURE RELIEF BYPASS VALVE	CASH / 3/4	340001

Model CC-200 R continued

## PARTS LIST

## TROUBLE SHOOTING

PROBLEM	CAUSE	SOLUTION
Cooler operative but not cooling	<ul style="list-style-type: none"> <li>A. Low Oil level</li> <li>B. Low Flow</li> <li>C. Dirty Air Filter</li> <li>D. Blocked Air Flow</li> <li>E. Low Refrigerant Charge</li> <li>F. Condenser Clogged</li> <li>G. Faulty Controller</li> <li>H. Faulty Compressor</li> <li>H. Incorrect Expansion Valve setting</li> <li>I. Incorrect Hot Gas Bypass Valve (HGPV) setting</li> </ul>	<ul style="list-style-type: none"> <li>Add Oil to sump</li> <li>Check pump rotation or for a restriction</li> <li>Clean</li> <li>Remove Blockage</li> <li>Repair *</li> <li>Clean</li> <li>Repair/Replace</li> <li>Repair/Replace*</li> <li>Adjust Expansion Valve to proper setting*</li> <li>Adjust Hot Gas Bypass Valve to proper setting*</li> </ul>
Cooler inoperative or does not start	<ul style="list-style-type: none"> <li>A. Faulty Power Source</li> <li>B. Pump Overload tripped</li> <li>C. Faulty On/Off Switch</li> <li>D. Faulty Solenoid Valve/Coil</li> <li>E. Cooler OFF on High Head Pressure</li>   <li>F. Cooler OFF on Low Suction Pressure</li> </ul>	<ul style="list-style-type: none"> <li>Check &amp; Correct</li> <li>Check Amps and Correct</li> <li>Repair/Replace</li> <li>Replace*</li> <li>Push Blue Reset Button on Pressure Switch.</li> <li>Check for: <ul style="list-style-type: none"> <li>Dirty Air Filter</li> <li>Dirty Condenser</li> <li>Bad Fan Motor</li> <li>Faulty Fan Pressure Switch</li> <li>Incorrect Expansion Valve or HGBV Setting*</li> </ul> </li> <li>Use Screwdriver to Push Up Manual Toggle on Pressure Switch to Restart Compressor.</li> <li>Check for: <ul style="list-style-type: none"> <li>No or Low Oil Flow thru Evaporator</li> <li>Low Ambient</li> <li>Wrong Setting on H/L Pressure Switch</li> </ul> </li> <li>If Compressor Does Not Continue to Run after Screwdriver is Removed, Check for: <ul style="list-style-type: none"> <li>Low or Lost Refrigerant Charge*</li> <li>Incorrect Expansion or HGPV Valve Setting*</li> </ul> </li> </ul>
Oil leaking	<ul style="list-style-type: none"> <li>A. Loose connection</li> <li>B. Faulty pump seal</li> </ul>	<ul style="list-style-type: none"> <li>Repair</li> <li>Repair</li> </ul>

*Model CC-200 R continued*

\* Actions designated with \* should only be done by a *Qualified Refrigeration Service Person*.  
Check with factory for proper settings.



230/60/3  
DISC

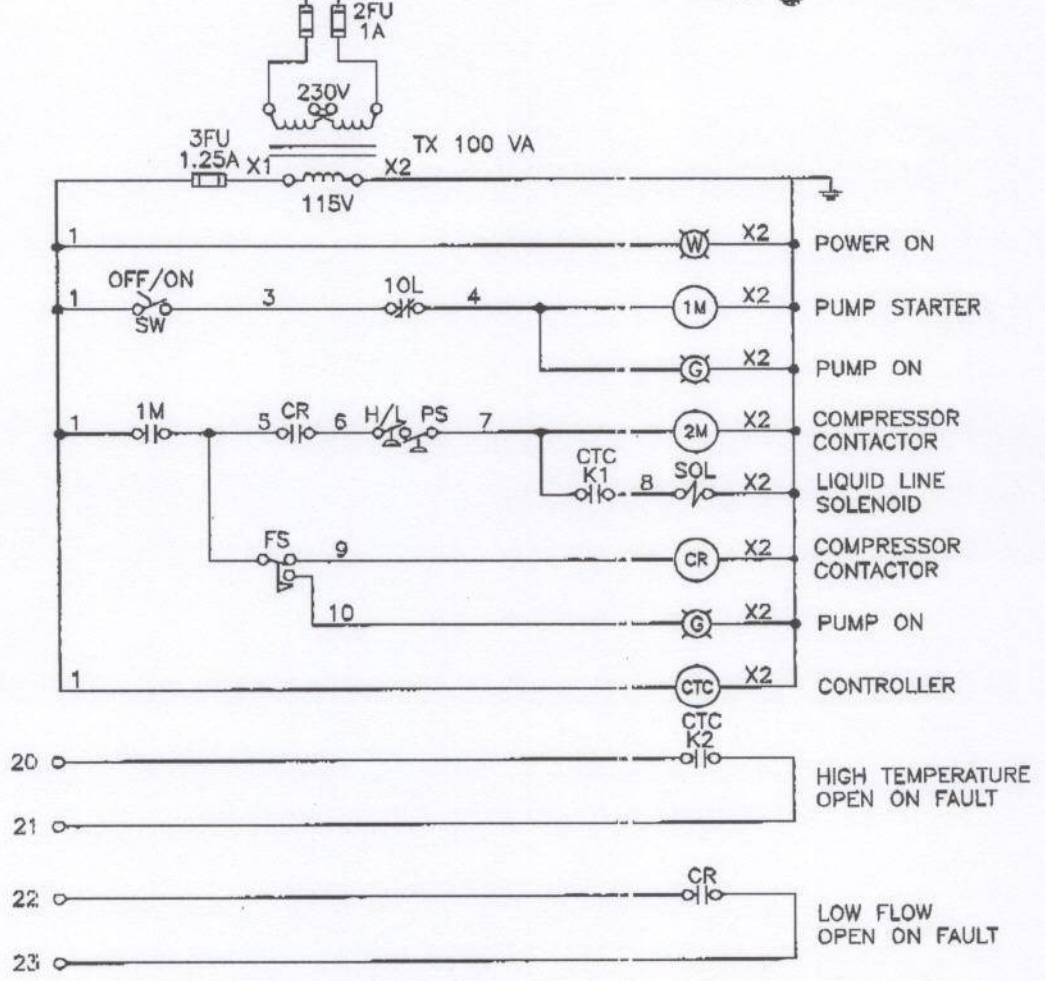
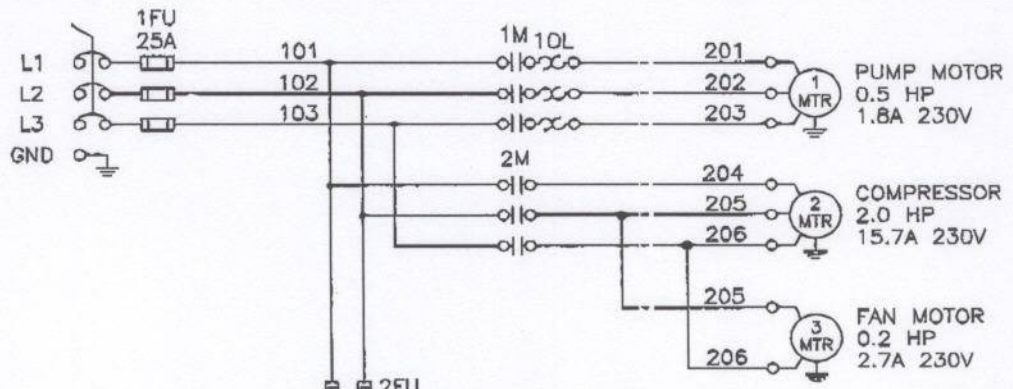

DRAWN BY: PH	S.O.# -	OC-200 R WIRING DIAGRAM		735 West Swanzey Road West Swanzey, NH 03469
DATE: 9/15/07	PAGE 1 OF 1			

GENERIC OC-200 R-HT-LF-230 ELEC

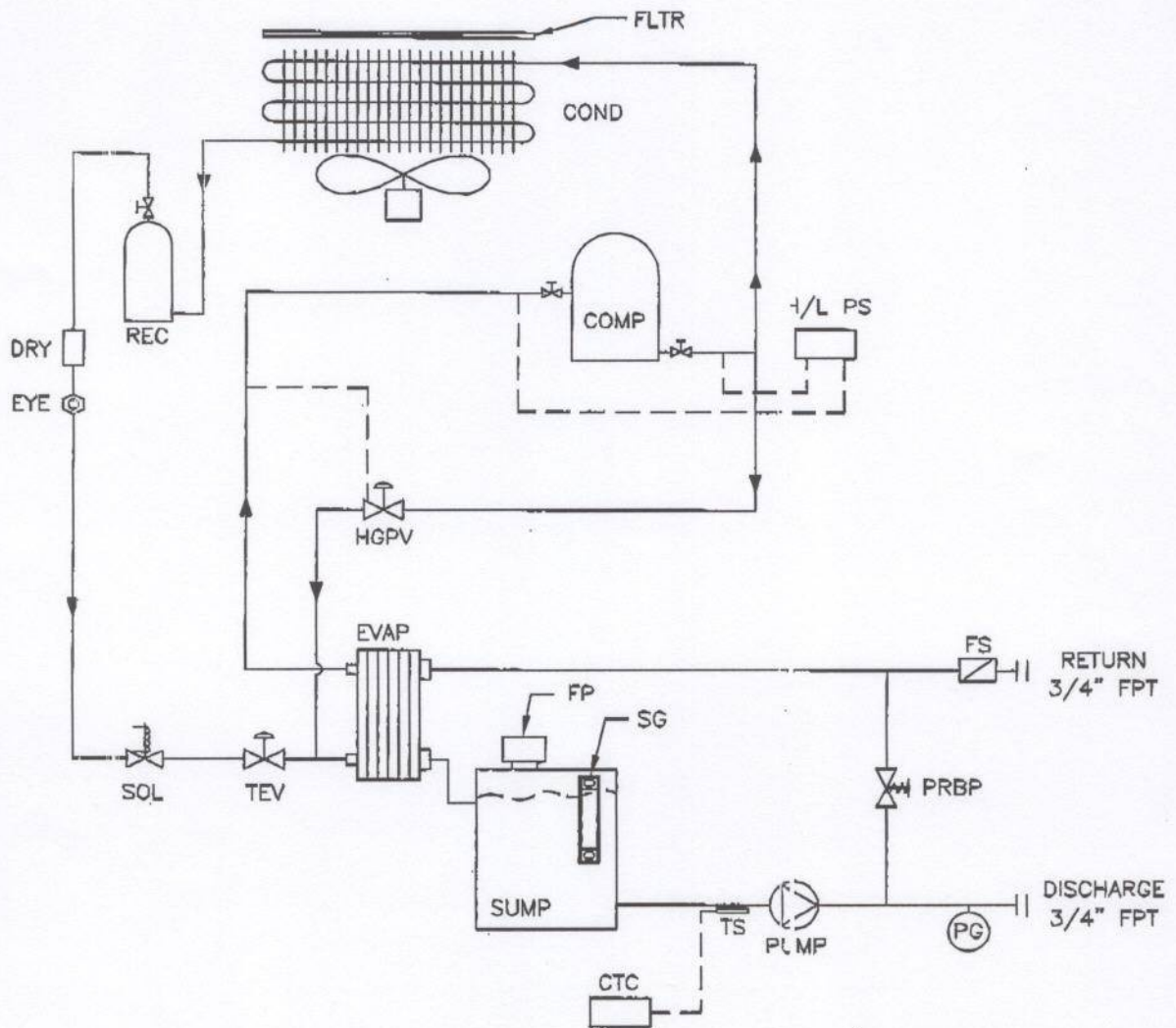

DRAWN BY: PH	SIZE:	S.O.#
DATE: 2/2/05	REV	PAGE -

OC-200 R  
FLOW DIAGRAM

**TURMOIL**

735 West Swanzey Road  
West Swanzey, NH 03469

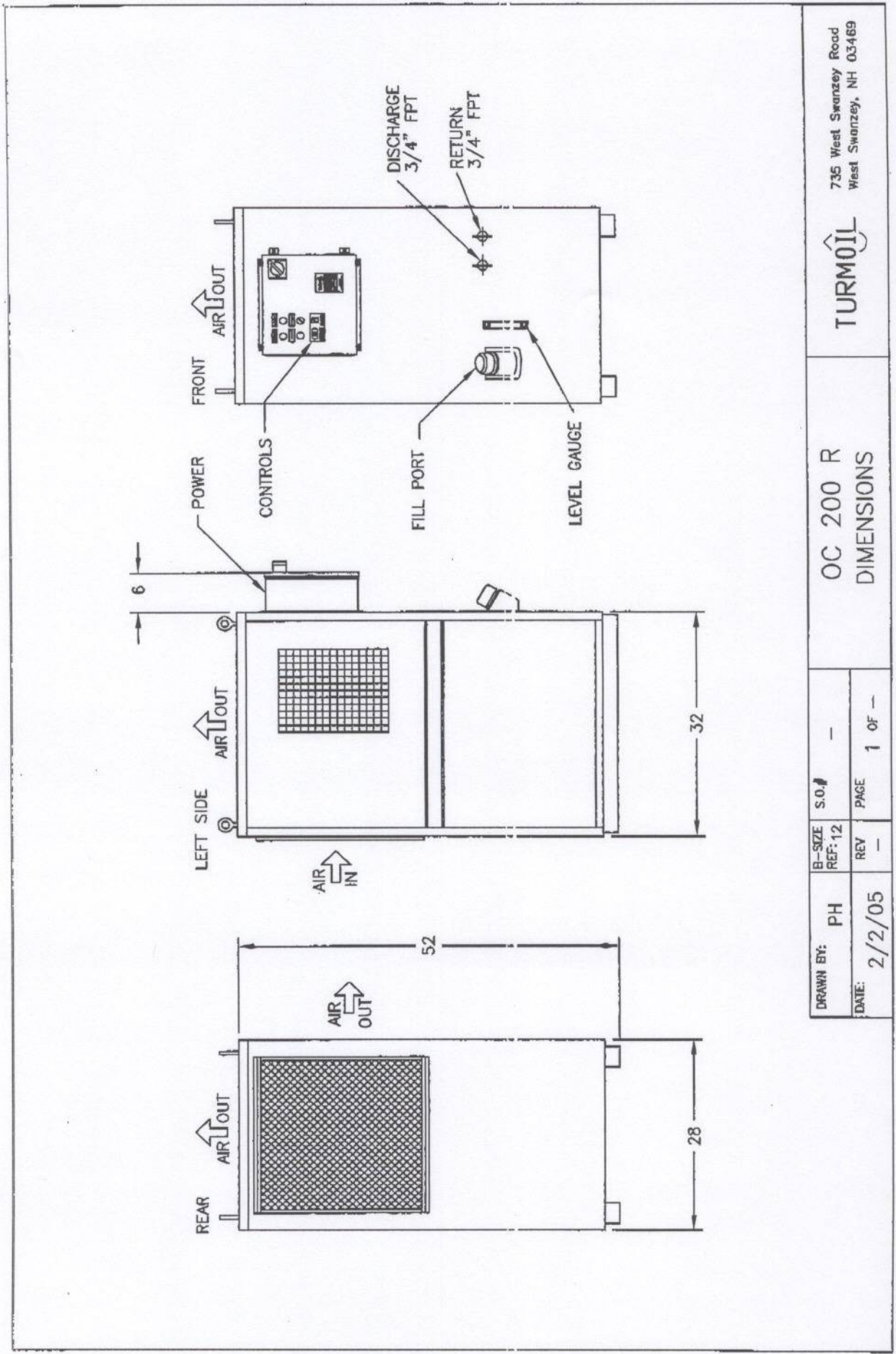

735 West Swanzey Road  
West Swanzey, NH 03469



OC 200 R  
DIMENSIONS

DRAWN BY: PH	B-SIZE REF: 12	S.O.#	—
DATE: 2/2/05	REV	PAGE	1 OF —